

upb
since 1991

AILE[®]
GRUPA

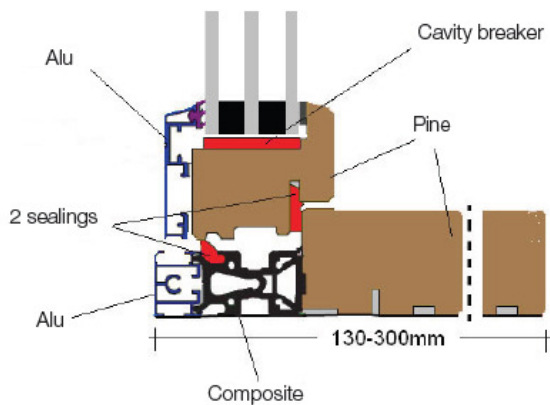
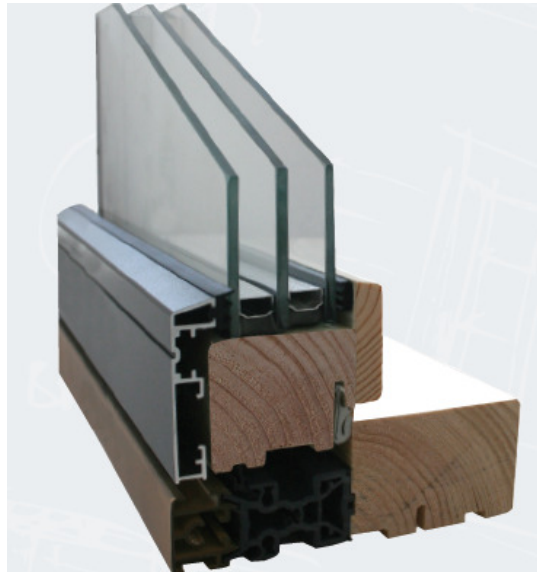

INSTALLATION MANUAL

FOR WOOD ALUMINIUM
GLAZED STRUCTURES

AILE COto

01/2015

CONTENT

1.	Components of a window	3
2.	Unloading and storage of elements	3
2.1.	On arrival	3
2.2.	Storage of windows/ doors	4
2.3.	Storage of insulating glass units	4
3.	Fixing to the building	4
3.1.	Window opening	4
3.2.	Fitting	5
3.3.	Temporary fixing	5
3.4.	Support	5
3.5.	Fixing	6
3.6.	Filling	8
3.7.	Fitting handle and cylinders	8
4.	Adjustment	9
5.	Glass removing and blocking	9
5.1.	Hanging the glass in opening windows/ fixed windows	9
5.2.	Removing the glass from a sash	9
5.3.	Removing the glass from fixed frame windows	9
5.4.	Blocking	10
6.	Protection of the visible frame surface	11
7.	Window cleaning	11
8.	Commissioning	11

These instructions are in addition to the standard instructions issued by Danish Window Certification (DVC).

1. COMPONENTS OF A WINDOW



2. UNLOADING AND STORAGE OF ELEMENTS

2.1. On arrival

Elements must be unloaded and handled with due care. On arrival they should be checked to ensure that elements correspond to the order confirmation, that they are free from defects and the quantity is correct. Should there be any defects or mistakes, the vendor or the plant should be informed about it within one week as of delivery (Refer "Operation and Maintenance Instructions for Wood Aluminium Structures").

Glass may be lifted using various hoists/lifts with a solid surface under the element or with assembly lift equipment. The element should always be positioned vertically – elements weighing under 30 kg may be lifted also by using the upper frame.

Please note!

Windows, doors and glass are delivered at the side of the delivery vehicle, and it is the customer's responsibility to unload. Similarly, it is the customer's responsibility to see that elements are correctly stored, and that they are protected against dirt, sun, water and snow at all times.

The wrapping of elements is to be considered as temporarily for transport and not for storage and cover against dirt, rain, sun or snow.

As soon as the goods are unloaded, responsibility is taken over by the customer.

2.2. Storage of windows/ doors:

All elements must immediately after delivery be protected against water, direct sunlight, dirt and other damage risks.

Supplied structures shall be stored vertically. It is not permissible to store structures horizontally or differently than provided for by their structure. The best storage conditions are indoor, on a smooth surface at a dry and clean place. Structures may not be stored directly on the ground. Alternatively the elements can be stored outdoor if the top and sides of the pallets are covered by water tight tarpaulins. The tarpaulins have to be fastened to avoid damage from windy weather, and in a way that allows air to circulate underneath the pallet (Refer "Operation and Maintenance Manual for Wood Aluminium Glazed Structures").

2.3. Storage of insulated glass units (IGU):

It is most important that IGU should be covered immediately. While storing IGU on site or in a warehouse, special attention should be paid not only to the above provisions, but also to solar and any other thermal effect on glass. IGU which are exposed to sunlight during storage absorb so much heat that they rupture thermally (Refer "Operation and Maintenance Manual for Wood Aluminium Glazed Structures").

3. FIXING TO THE BUILDING

The quality of a high quality window depends on the installation. For this reason the professional fastening and the soundness of the connection are of vital importance.

3.1. Window opening

Fully finished windows should be installed into preformed openings. Building in fully finished windows during the course of construction should be avoided if possible. Where this is not possible, the materials adjacent to the opening should not be fitted tightly to prevent distortion of the frame. Side tolerances should not exceed 10mm on each side. When not building in, openings can be formed using either proprietary cavity closers or site constructed templates. These templates should produce openings that are between 10mm to 20mm larger than the actual window size.

When attaching window and door elements, please note: blocking up and fixing must be carried out with the DVC directions as a minimum standard, i.e. never more than 900mm centres between fixing points – always under or close to bearing mullions or transoms and always under door sills etc. (A and B), see Figure 1.

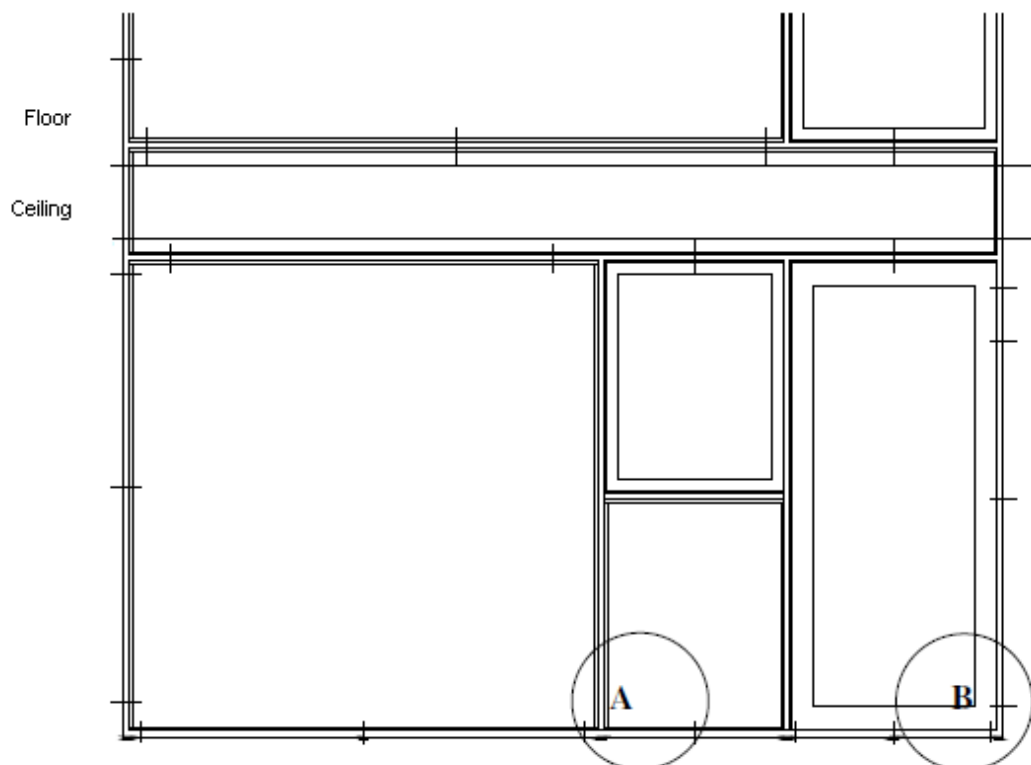

Figure 1 . Typical frame fixing points – max 900mm centres

NB! That the element must be positioned in the building and horizontally and vertically aligned before fixing. Check the element via cross-measurements.

Screws placed in the composite bottom casing must be sealed with silicone at the screw head before tightening.



Windows and doors should be installed in the warm part of the wall (below the dew-point) to avoid condensation building on the coldest parts of those building elements.

3.2. Fitting

Fully Damp Proof Courses (DPC) should be fitted during construction, either by fixing to the frame prior to building-in or by fitting the DPC into the structure when making pre-formed openings.

To reduce the amount of heat lost from the inside of the building to the outside through the window edges (a cold bridge *tech.*), the window must be set back to overlap the inner face of the outer works by at least 30mm. Adequate insulation should be fitted between the outer and inner wall construction to reduce heat loss around the wind opening.

3.3. Temporary fixing

For temporary fixing and leveling (both – vertically and horizontally) wooden or plastic blocks can be used. Bearing blocks must be made of solid hard wood or plastic. After leveling it is important to check diagonal length equivalence especially of the opening parts. Layout scheme of the blocks is described in Figure 2.

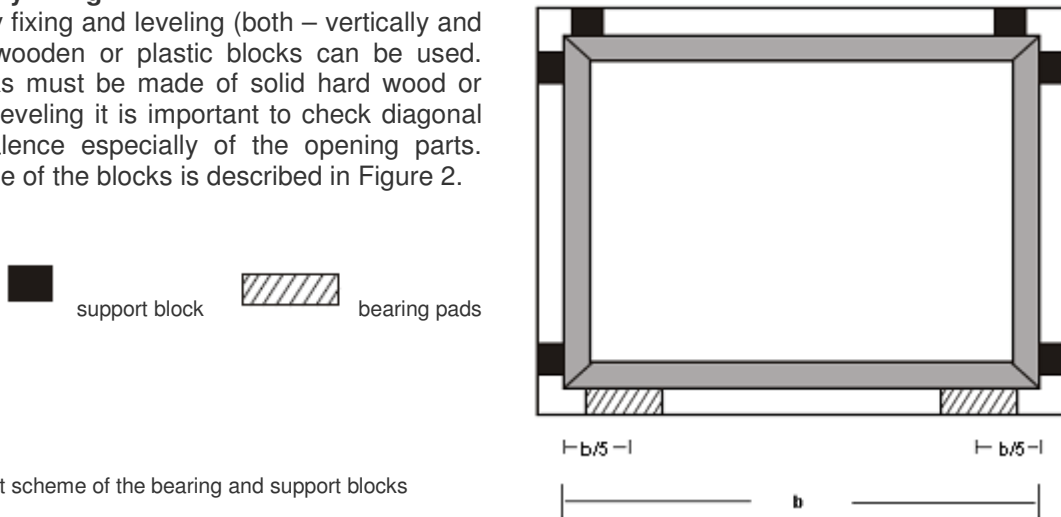

Figure 2. Layout scheme of the bearing and support blocks

3.4. Support

Windows should be fitted level and plumb: failure to do so can impair the function of the window openings and hardware and may also result in cracking of the glazed units.

The windows should be supported on durable blocks at a maximum of 150mm from each jamb and beneath the mullions. Side blocks should be located where fixings occur and should not distort the frame. The frame should be supported so as to prevent distortion and not damage any protection or finish.

The element must always be chocked up just under the side casings. Note that the chocking must always be performed so that both aluminium and wooden frames are supported. If the element contains a vertical mullion, chocking must also be directly under the mullion.

The bearing pads are recommended to leave in the windows according to opening direction.

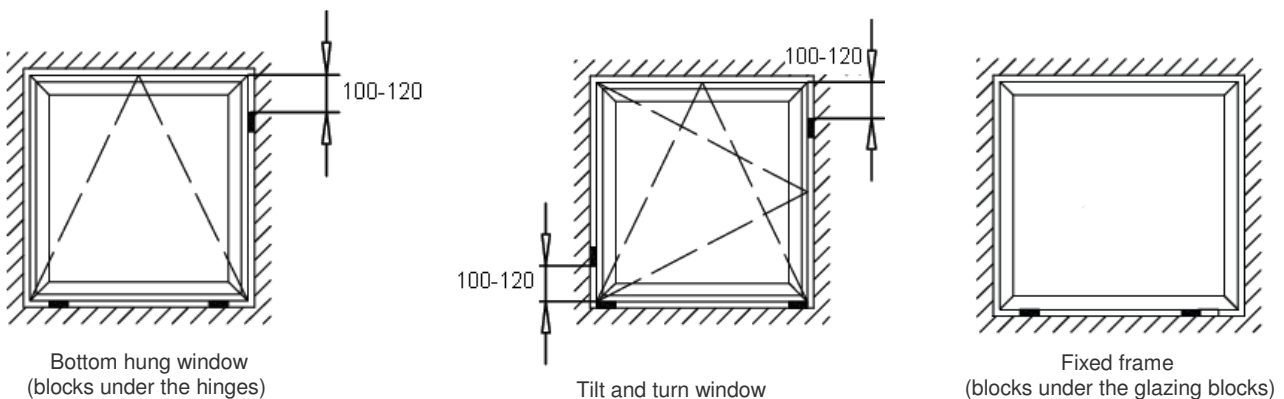

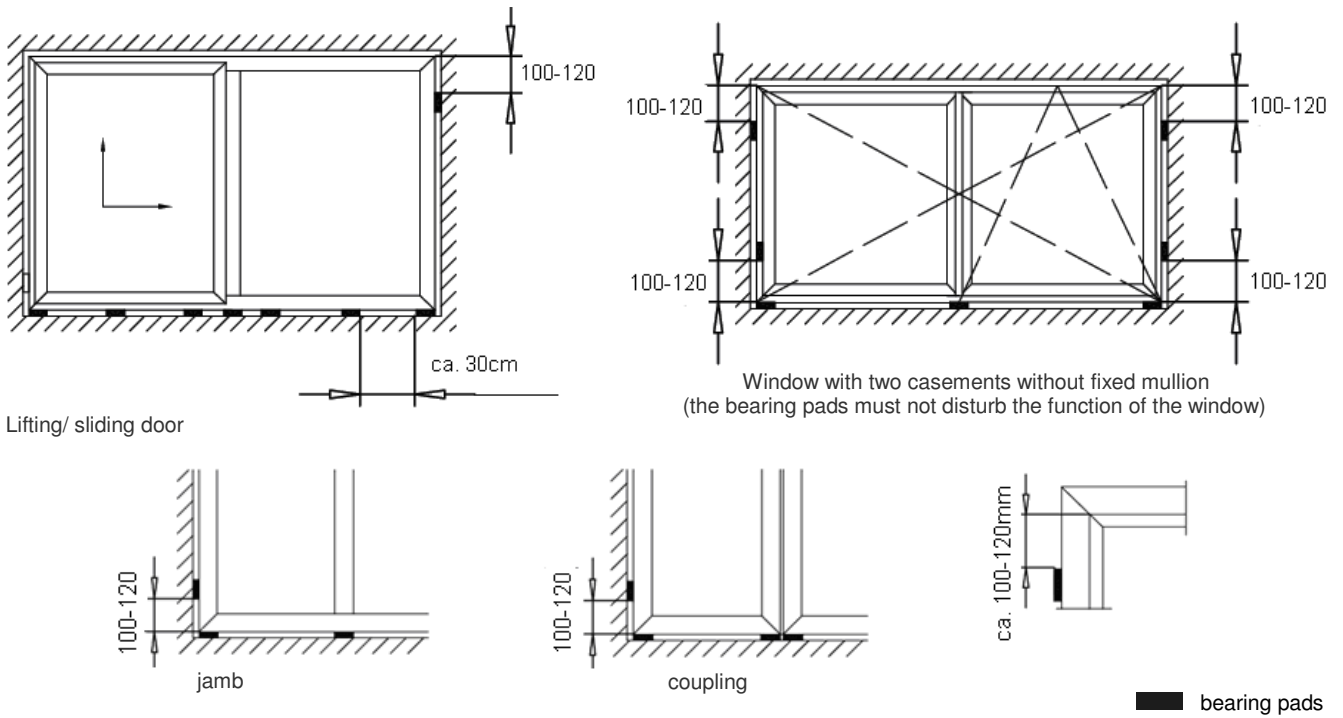

Figure 3. Layout scheme of the bearing pads

3.5. Fixing

Please make sure the fixing method chosen is appropriate – fixing with Adjufix anchors, with screws or with brackets. Recommended method for system Aile COto – fixing with **Adjufix anchors**:

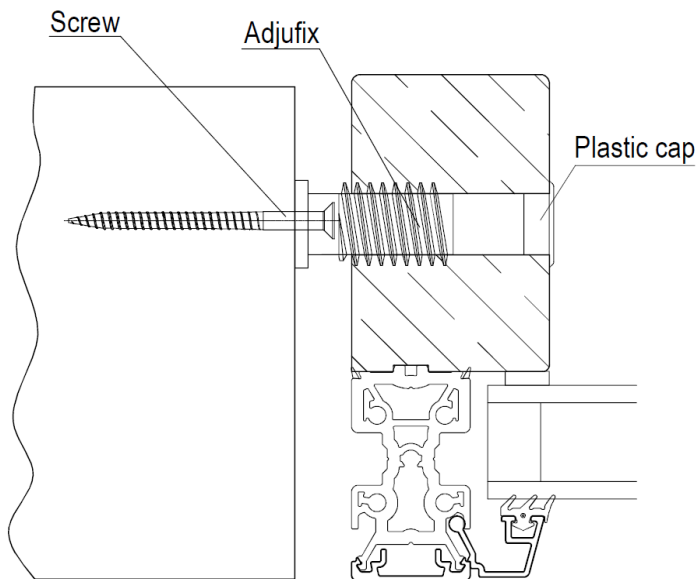

Figure 4. Fixing with Adjufix

- Lift into the window/door opening;
- Adjust the frame in the correct position with Adjufix;
- Fasten fixing screws: when mounting to concrete, aerated concrete etc. the hole must be drilled through the Adjufix.

When necessary, readjust the frame to the correct position.

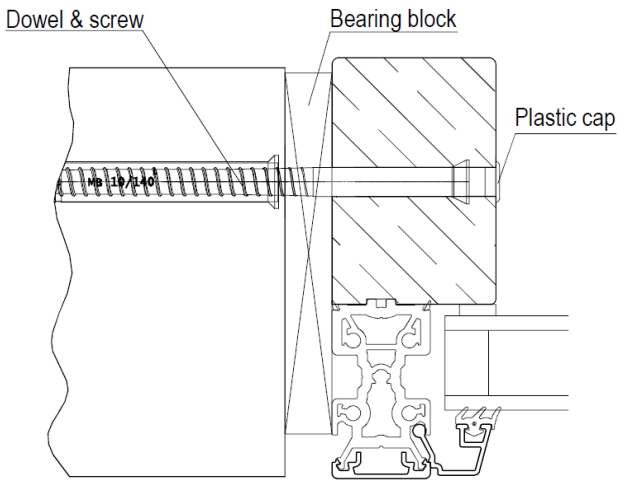

Figure 5. Fixing with screws

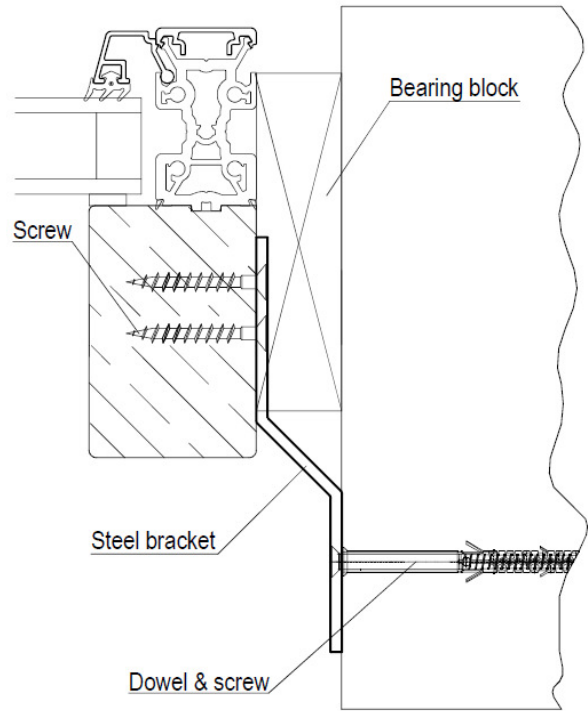

Figure 6. Fixing with brackets

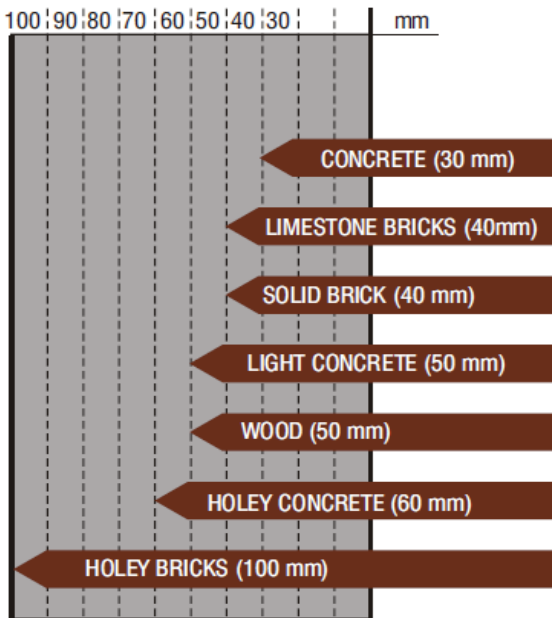
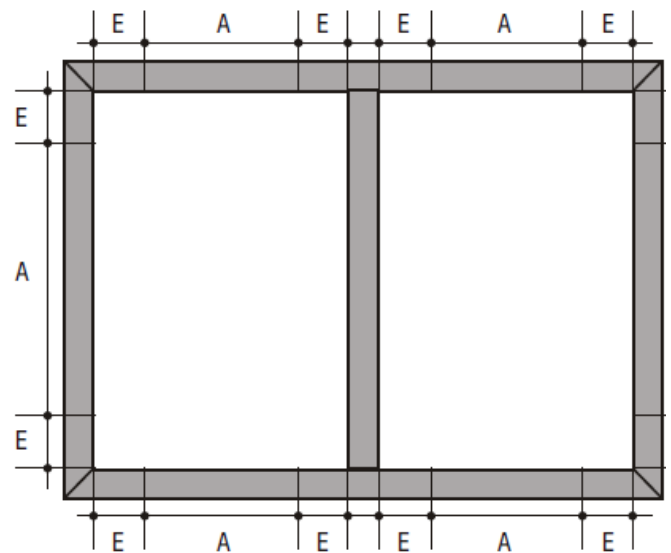

Figure 7. Recommended drill fastening in various materials



- = attachment points
- A = distance of the fixing points ca.700mm
- E = distance of the inner corner profile ca.100-120mm

Figure 8. Distances for the fastening of windows



! When mounting the doors that have heat-insulating frame in composite must be inserted screws in the hinges, which goes directly into the vertical load-bearing wall.

The hinges are constructed with a 6mm hole for direct wall mounting. There are normally used 6x90 or 110mm frame screws (AMO). It is sufficient to secure the hinges with frame screw after insertion and adjustment.

Figure 9. Mounting the doors

3.6. Filling

To prevent air and moisture passage between the window and the adjacent wall, the gap should be completely filled with insulating material (1-component or 2-component polyurethane foam, glass wool, rock wool, cork, insulation tape) and sealed. Various sealing methods can be used, e.g. expanding closed cell foam or a silicone or mastic sealant.



Insulation materials used stay dry during installation. Otherwise, they will not maintain their insulating function.

PU-foams establish more or less pressure during the curing, this pressure has to be absorbed by the window construction.

If excess sealant spreads over the painted surface, in order to avoid aesthetic damage, clean it off as soon as possible: Do not allow it to set. When installation works are done in a winter time (below zero degrees), so called "winter" construction foam or filler materials are to be used. After foam has cured, leftover must be cut off. In order to ensure thermal insulation, foam should be sealed with silicone or alternative sealing materials.

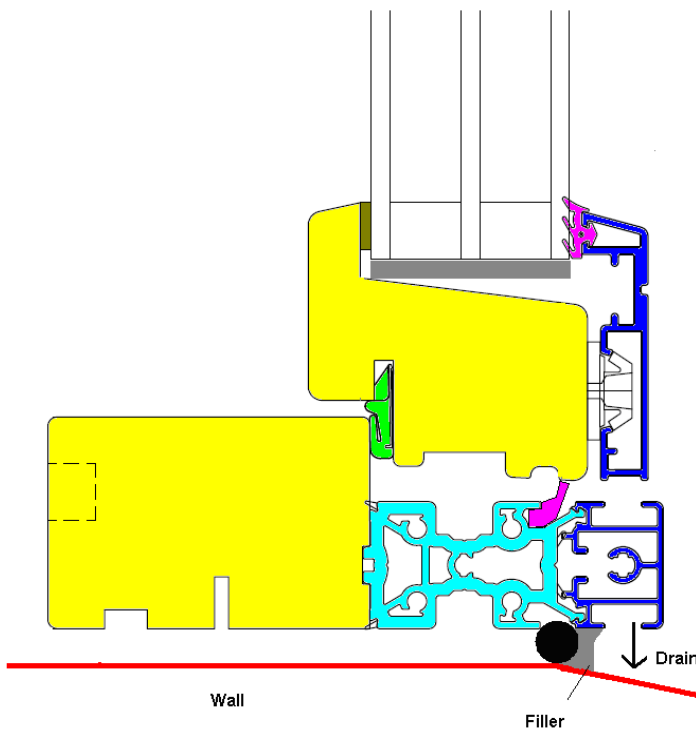

Never block the drain holes in the bottom frame/sash with sealant.

Figure 10. Sealing for drainage

3.7. Fitting handle and cylinders

Handles are supplied unfitted within the window packaging to prevent damage during transport and handling. The windows openers are pre-drilled to accept the handle screws. Do not over-tighten the screws during fitting, e.g. by using a power drill driver with the incorrect torque setting.

When fitting door handles and cylinders, remember to seal and tighten under the rosettes before screwing them on. The reason for this is that gaps under rosettes or back plates often mean that water can seep into the lock case or espagnolette system and not least down onto the floor.

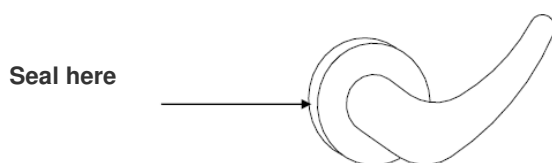

4. ADJUSTMENT

Adjustment of the frame/sash can be made via the adjustment screws. The adjustment screws can be found on the frame and sash part.

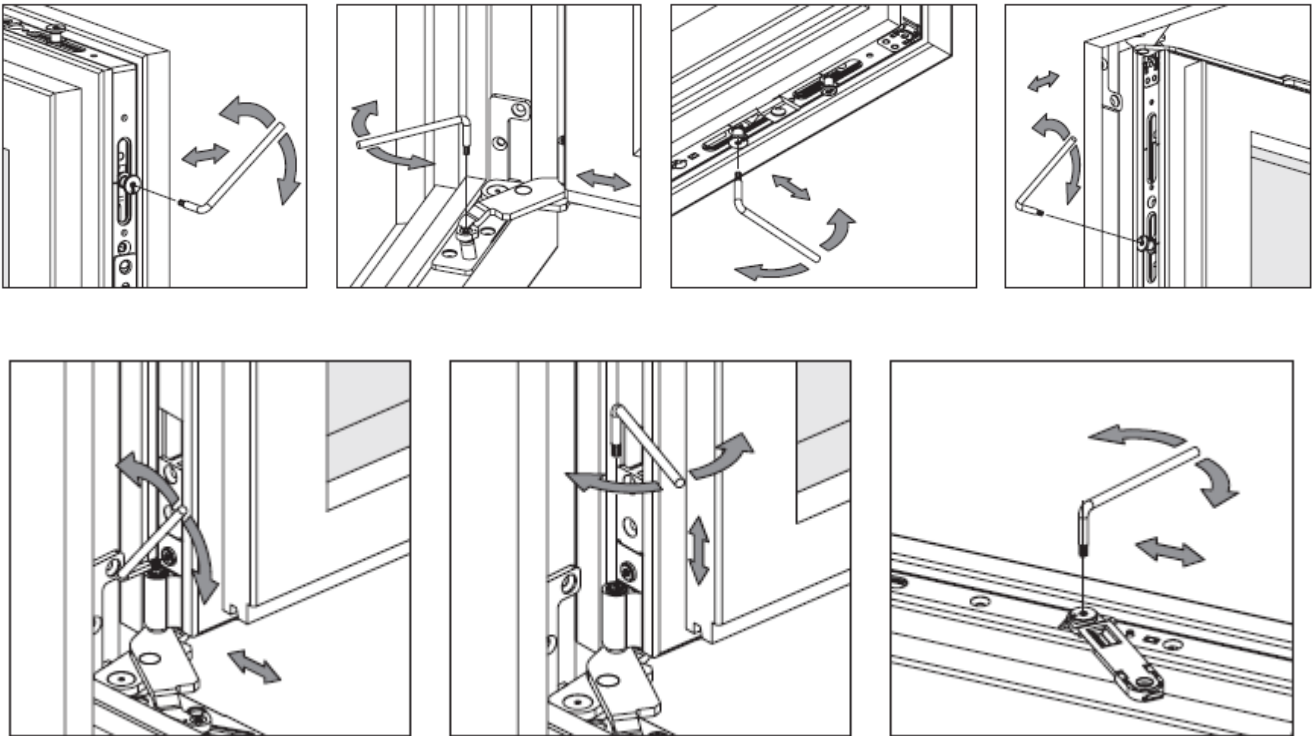

5. GLASS REMOVING AND BLOCKING

5.1. Hanging the glass in opening windows/ fixed windows

The IGU in our windows and doors conform to Dansk Vindues Certificering (DVC) standards and installation of the glazed window panes is performed in accordance with the assembling requirements of DVC. However, the frame packers should be laid 20mm from the side frames/posts. This is done to avoid bending the horizontal post under the weight of the glass.

Glass is usually delivered fitted from the factory, but it if specially requested or if stated on the order confirmation, glass (or panels) for fixed sections can be delivered separately for the customer to install the glass on site.



To retain the factory warranty please make sure that the insulating glass units are handled only by trained window installation experts.

Glass is marked with the order number and window type for easy identification – see the info-marking on the glass. It is then easy to match the frame with the glass to be installed.

5.2. Removing the glass from the sash

- Carefully remove the exterior gasket on the outer edge of the sash;
- Place a polished 19mm fork key between the wooden sash and the aluminium profile in the sash; turn the plastic spacer clips 90° so that the aluminium cover profile comes free of the sash. The plastic spacer clips are located approx. every 100-150mm;
- Lift off the aluminium cover profile and take out the insulating glass unit. After re-assembling please turn the clip 90° and tap on the sash with a rubber mallet carefully.

5.3. Removing the glass from fixed frame windows

- Carefully remove the glazing bead with the help of, for example, a stronger putty knife;
- Lift the IGU out of the frame. After replacing, please push back the glazing beads into the groove, first horizontal, then vertical ones. The glazing bead is easier to push down if a little bit of soapy water is applied to the glass and gasket beforehand.

The min gap between glazing unit and rebate is 4mm.

For the blocks to function properly they must be fixed in the prescribed position. Nails, pins etc. must not be used to fix blocks in a manner that may damage the IGU. The position of the blocks must not impede the compression or the sealing properties of the glazing bead against the glazing unit.

5.4. Blocking

- ▲ **Setting blocks** - must always be used. Setting blocks transfer loads between glazing units and rebate while also contributing to the overall stability of the unit. The gap to a glazing unit corner must always exceed 50mm. In case the glazing unit is supported by one block only, e.g. in turn window, the block must have a length of 10mm for glazing units less than 2m² and otherwise 200mm.
- **Guide block** - ensure the gap between glazing unit edge and rebate. Measured from the corner of the glazing unit edge the gap must exceed 50mm.
- × **Riser block** - if necessary, a riser block may be used to ensure the functioning of the hardware and the centering of the glazing unit during transport and operation. The length must be at least 5mm for glazing unit less than 2m² and otherwise 100mm.

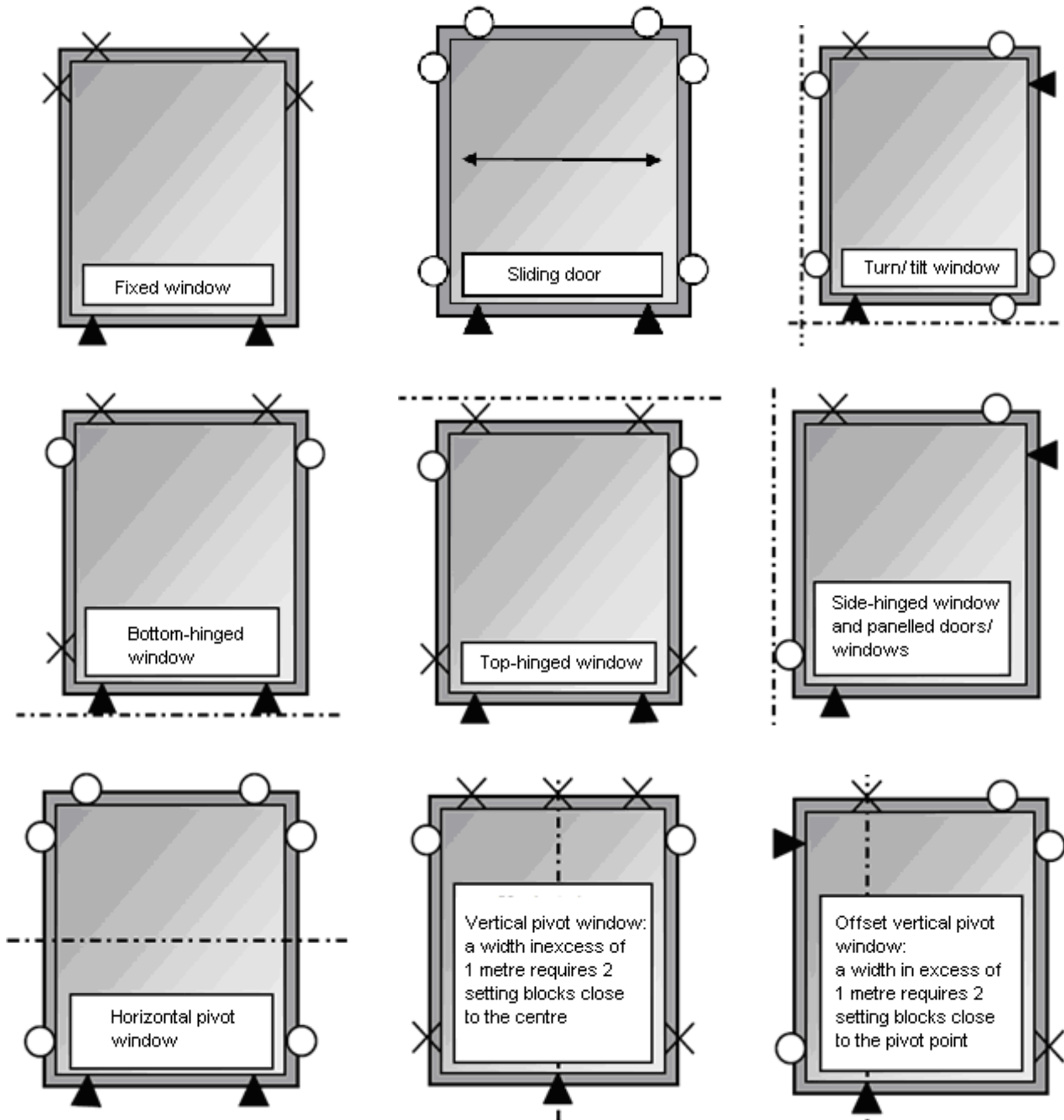

Figure 11 . Layout scheme of blocks for windows of different types

6. PROTECTION OF THE VISIBLE FRAME SURFACE

“Operation and Maintenance Manual for Wood Aluminium Glazed Structures” applies to the protection of the completed units. If the visible surfaces are not covered at the factory, it is advisable to cover them with a protective plastic foil as protection of the frame surfaces against soiling or installation damages, PU-foams etc. These protective foils, even if they are applied at the factory, shall be removed after the installation.

7. WINDOW CLEANING

The cleaning of the windows includes the removal of any contamination, which is caused during installation by the consignee. Only cleaning agents recommended by the windows manufacturer are to be used (Refer “Operation and Maintenance Manual for Wood Aluminium Glazed Structures”).



Do not use high pressure cleaner for cleaning glazed structures!

8. COMMISSIONING

Before commissioning the person-in-charge should make sure whether:

- sealing strips, assembly elements and grooves are cleaned and do not have any plaster left, drilling dust and other construction dirt left;
- opening parts are installed and adjusted and operate properly;
- hinges and closure fittings are adjusted and operate properly;
- all moving parts, excluding friction parts, are oiled with an appropriate lubricant;
- any surface damages are eliminated ;
- users are instructed regarding proper operation of the elements;
- users are informed of the necessity of ventilation to avoid condensate.

Please note:

- to avoid condensate on glass and moisture absorption, the building requires ventilation;
- recommended air moisture in premises where our structures are installed, is 50-60%, air temperature at least +18°C (Refer “Operation and Maintenance Manual for Wood Aluminium Glazed Structures”).

upb
since 1991

AILE[®]
GRUPA

SIA „Aile Grupa”
Glazed structures, windows, doors, facades

Pulvera 28, Liepāja
Latvia, LV- 3405

Phone.: (+371) 63489300

Fax: (+371) 63489301

Maskavas 250, Rīga
Latvia, LV - 1063

Phone: (+371) 67813800

Fax: (+371) 67813801

info@ailegrupa.lv

www.ailegrupa.lv

www.upb.lv